

# WINCHES



SINCE 1958

TOWING & ANCHOR HANDLING

DW-275

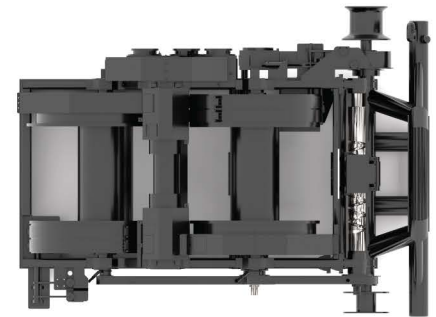
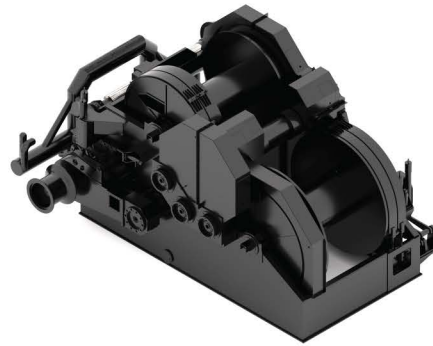
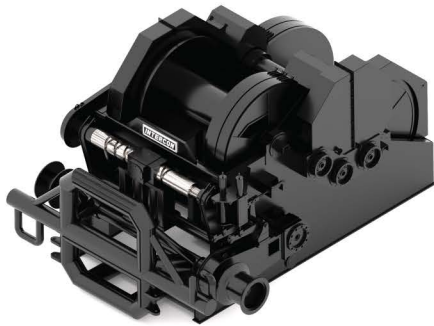

## DW-275 Double Drum Reverse Waterfall Towing Winch

### Specifications

**Max Line Pull:** 253 tn @ 19 fpm

**Light Line Pull:** 47 tn @ 103 fpm

**Storage Capacity:** 4200 ft

**Rope Diameter:** 2.75 in

**Brake Capacity:** 700,000 lb

**Weight W/O Wire:** 135,000 lb

INTERCON winches and deck machinery operate worldwide in a wide range of applications. For over 50 years, Intercon has designed and manufactured deck equipment to meet the exact needs of its customers – whether that need is met from Intercon's full line of standard products or from customized one-of-a-kind machines or systems.

**INTERCON.COM**

info@intercon.com  
+1 (816) 741-0700